

PROPRIETARY NOTICE

All rights reserved by Janz Tec AG.

No parts of this technical manual may be modified, copied or reproduced in any form or by any means for commercial use without the prior written permission of Janz Tec AG, Germany.

All instructions, information and specification contained in this manual are for reference only and remain subject to change without announcement.

emPC-X

embedded PC

(Hardware Manual)

Version 1.4

refers to product revision no.

x.x

Title: emPC-X embedded PC
File: j:\as\entwicklung\projekte\hw\empc\empc_x1600\doc>manual\manual_empc-x hardware.doc
Pattern: \\ntserv5\janzgrp\as\entwicklung\formulare\entwicklung (ew)\ew_manual.dot
Created: Stefan Althöfer, 21.05.2014
Last Update: Tom Karpen, 06.07.2022

© Janz Tec AG 2015

Im Dörener Feld 8
D-33100 Paderborn, Germany

Tel.: +49-5251-1550-0
FAX: +49-5251-1550-190
email: support@janztec.com
Internet: www.janztec.com

Contents

1	Introduction	5
1.1	Features	5
1.1.1	Standard Products	5
1.1.2	Hardware Customization	6
1.1.3	Software	7
1.2	Functional Overview	8
2	Safety Instructions	9
2.1	Installation and Maintenance	9
2.2	Ambient and Environmental Conditions	9
3	Intended use	10
3.1	Disposal and Recycling	10
3.1.1	EU	10
3.1.2	Germany	10
4	Installation	11
4.1	Mounting	11
4.2	Connectors and Operators	13
4.2.1	POWER IN	14
4.2.2	Graphics connector (DVI)	14
4.2.3	Ethernet Interfaces (Ethernet1 and Ethernet2)	15
4.2.4	USB type A receptacle (USB0, USB1 and USB2)	15
4.1	RS232 (Console)	15
4.2	RS232	16
4.3	RS485	16
4.4	CAN	17
4.5	SD Card	18
5	Maintenance	19
5.1	CFast Card Replacement	19
5.2	Battery Replacement	20
6	Appendices	21
6.1	Technical Data	21
6.2	References	23
6.3	Dimensions	24
6.4	Product History	25
6.5	Manual History	25

List of Figures

figure 1: block diagram (2 PCB variant shown)	8
figure 2: emPC-X mounting options	11
Figure 3: emPC-X/0 interfaces	13
Figure 4: emPC-X/1 interfaces	13
Figure 5: emPC-X/2 interfaces	13
Figure 6: emPC-X/4 interfaces	13
Figure 7: Power connector	14
figure 8: RS485 signaling	16
figure 9: emPC-X SD card cover removal	18
figure 10: emPC-X back panel removal.....	19
figure 11: Removing and replacing coin cell battery	20
figure 12: housing dimensions (2 DSUB system shown)	24

List of Tables

Table 1: emPC-X standard products	5
Table 2: Interfaces connected to D-SUB.....	13
Table 3: Power connector pin assignment	14
table 4: DVI-D connector	14
table 5: Ethernet connector	15
table 6: USB connector.....	15
table 7: RS232 (Console) connector	15
table 8: RS232 connector	16
table 9: RS485 connector	16
table 10: CAN connector	17

About this Manual

This is the hardware manual for the emPC-X embedded PC.

Throughout the manual, the term emPC-X is used to identify the all systems. When required, the CPU options are identified explicitly.

Conventions

If numbers are specified in this manual, they will be either decimal or hexadecimal. We use C-notation to identify hexadecimal numbers (the 0x prefix).

If we refer to low active signal names, they will suffixed by a “#” character.

Some parts of the contains notices you have to observe to ensure your personal safety, or to prevent damage to property. These are visually marked with the following alert symbols:

	DANGER Indicates that death or severe personal injury <i>will</i> result if proper precautions are not taken.
-----------------------------------------------------------------------------------	-------------------------------------------------------------------------------------------------------------------------

	WARNING Indicates that death or severe personal injury <i>may</i> result if proper precautions are not taken.
-----------------------------------------------------------------------------------	-------------------------------------------------------------------------------------------------------------------------

	CAUTION Indicates that <i>minor</i> personal injury can result if proper precautions are not taken.
-------------------------------------------------------------------------------------	---------------------------------------------------------------------------------------------------------------

	NOTICE Indicates that damage to equipment can result if proper precautions are not taken.
-------------------------------------------------------------------------------------	-----------------------------------------------------------------------------------------------------



Indicates information that we think you should have read to save your time by avoiding common problems. Important suggestions that should be followed will also be marked with this sign.

Acronyms and Abbreviations

EMC	Electromagnetic capability.
ESD	Electrostatic discharge.
GND	System ground potential. Inside the product this is connected to the metal housing, which might be connected to protective earth by the installation. There exist some isolated reference grounds for communication interfaces or IO. These reference signals are referred to as GND-x, where x indicates function.
SELV	Safety extra low voltage.

1 Introduction

The emPC-X platform is a flexible computer system. It consists of one CPU board and can be expanded with a variety of IO expansion boards. The boards are stacked together and are inserted into a rail mounted housing. This allows flexible system building. Internal busses are documented, so users can build application specific IO expansion boards.

Order-No.:	Product	Interfaces
SY-EPC-40001	emPC-X/A-E3815/0	ATOM E3815, 2 GB DDR2, DVI, 3 x USB 2.0, 2 x Ethernet, 2 x RS232 (console)
SY-EPC-40000	emPC-X/A-E3815/1	ATOM E3815, 2 GB DDR2, DVI, 3 x USB 2.0, 2 x Ethernet, 1 x RS232 (console). 1 x CAN/CANopen
SY-EPC-40002	emPC-X/A-E3815/0	ATOM E3815, 2 GB DDR2, DVI, 3 x USB 2.0, 2 x Ethernet, 2 x CAN/CANopen
SY-EPC-40004	emPC-X/A-E3815/4	ATOM E3815, 2 GB DDR2, DVI, 3 x USB 2.0, 2 x Ethernet, 4 x CAN/CANopen
SY-EPC-41001	emPC-X/A-E3825/0	ATOM E3825, 2 GB DDR3L, DVI, 3 x USB 2.0, 2 x Ethernet, 2 x RS232 (console)
SY-EPC-41000	emPC-X/A-E3825/1	ATOM E3825, 2 GB DDR3L, DVI, 3 x USB 2.0, 2 x Ethernet, 1 x RS232 (console). 1 x CAN/CANopen
SY-EPC-41002	emPC-X/A-E3825/0	ATOM E3825, 2 GB DDR3L, DVI, 3 x USB 2.0, 2 x Ethernet, 2 x CAN/CANopen
SY-EPC-41004	emPC-X/A-E3825/4	ATOM E3825, 2 GB DDR3L, DVI, 3 x USB 2.0, 2 x Ethernet, 4 x CAN/CANopen
SY-EPC-43000	emPC-X/A-E3940/0	ATOM E3940, 4 GB DDR3L, DVI, 3 x USB 2.0, 2 x Ethernet, 2 x CAN/CANopen
SY-EPC-43001	emPC-X/A-E3940/1	ATOM E3940, 4 GB DDR3L, DVI, 3 x USB 2.0, 2 x Ethernet, 1 x RS232 (console). 1 x CAN/CANopen
SY-EPC-43002	emPC-X/A-E3940/4	ATOM E3940, 4 GB DDR3L, DVI, 3 x USB 2.0, 2 x Ethernet, 4 x CAN/CANopen

Table 1: emPC-X standard products

1.1 Features

1.1.1 Standard Products

- Intel ATOM E3Xxx CPU
- 512 kB to 2 MB of L2 cache
- Up 4 GB DDR3L 1066 MT/s
- Fanless cooling concept
- 128 kB of MRAM which does not require battery backup

- Internal CFast Socket for SATA SSD
- SD card socket (Option)
- DVI-D graphic interface on front panel (Single Link)
- Single channel LVDS on internal connector
- 2 x 10/100/1000 Mbit/s Ethernet
- 3 x USB 2.0 interface (480Mbit/s)
- Battery backed up RTC
- System Power supply 9..34 VDC
- Reset Push Button and Power LED
- 2 male 9pin D-SUB connectors, utilized by serial ports or CAN
- Power supply monitor

1.1.2 Hardware Customization

Due to it's flexible system architecture, the emPC-X can be customized if the standard products do not provide optimum features or price. Customization is possible even at moderate quantities. Ask sales department for details.

Following you find a (non-complete) list of possible customization:

- Without MRAM for price reduction.
- Serial ports can be modified for RS485 physical layer (optionally isolated)
- More CAN ports are possible by using expansion cards (in a larger housing)
- More serial ports are possible
- Digital/Analog-IO expansion card
- Customer specific expansion cards
- Other mounting options (e.g. flange mount)

1.1.3 Software

Supported by

- Windows 7, Windows 8
- Windows 7 Embedded Standard
- Windows 10 IoT
- Linux

Contact Janz Tec for more information about the available software packages.

1.2 Functional Overview

The emPC-X is built upon a couple of standard building blocks, as shown in figure 1.

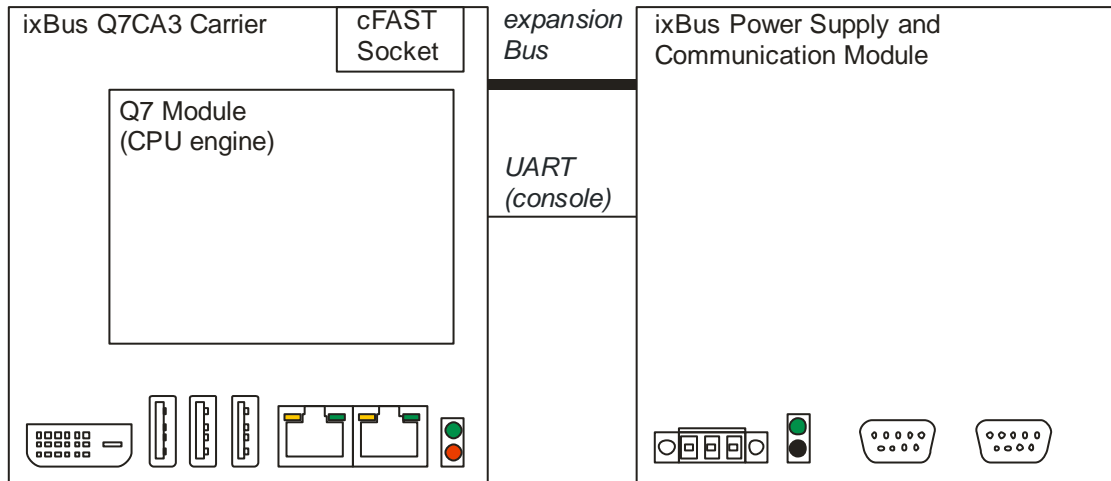

figure 1: block diagram (2 PCB variant shown)

The system consists of the following building blocks:

- Congatec Q7 module (QA3 series)
- Janz Tec ix-Bus Q7CA3 carrier module
- Janz Tec ix-Bus power supply and communication module
- Optionally additional IO modules

Refer to Congatec documentation for details on the Q7 Module.

Refer to Janz Tec ixBus System Reference Manual for details on the Janz Tec specific building blocks.

2 Safety Instructions

Refer to page iii for explanation of the warning notice system.

The product described in this documentation may be operated only by personnel qualified for the specific task in accordance with the relevant documentation for the specific task, in particular its warning notices and safety instructions. Qualified personnel are those who, based on their training and experience, are capable of identifying risks and avoiding potential hazards when working with these products.

2.1 Installation and Maintenance

**DANGER: Electrical Shock**

Danger to life.

This product operates with 9.34 V DC SELV power supply. Do not connect this product to an improper power supply.

**DANGER: Electrical Shock**

Danger to life.

The IO interfaces (connectors) of the product are only suited to be connected to SELV circuits. Use interfaces (connectors) for their intended use only.

**CAUTION: Explosive Risk**

The installed computer board is equipped with a Lithium battery.

Danger of explosion if battery is incorrectly replaced. Replace only with battery of the same or equivalent type.

**WARNING: Burns Hazard**

The product generates considerable amount of heat. The housing transports this heat to the environment and therefore gets hot. **Caution when touching the housing, burns hazard!**

2.2 Ambient and Environmental Conditions

**DANGER: Explosive Risk**

Do not operate the product in potentially explosive atmosphere.

**WARNING**

This product does **NOT** fulfil the requirements for a fire enclosure according to EN 60950-1 in all possible mounting positions. In these mounting positions, installation is only permitted above concrete or other non inflammable materials.

**CAUTION: Damage**

Do not operate the product beyond the specified ambient conditions. Do not cover the vent slots of the product.

**NOTICE: EMI**

This product is a class A device. This product may cause radio interference. In this case the user must take adequate measures.

3 Intended use

The emPC-X is designed for computing purposes in industrial environments. It is destined to be used indoor only.

3.1 Disposal and Recycling

Janz Tec products are manufactured to satisfy environmental protection requirements where possible. Some of the components used are capable of being recycled. Final disposal of this product after its service life must be accomplished in accordance with applicable country-, state-, or local-laws or -regulations.



This product contains a lithium battery. This should be removed before disposal and be returned separately



Don't forget to delete all sensitive data on the product before disposal. Especially delete all person related data.

3.1.1 EU

Janz Tec electronic products are labelled with the crossed-out trash can. This means that the products **must not** be disposed into the domestic garbage.

Used Janz Tec products have to be recycled properly. If in doubt, you can return them to Janz Tec at your own expense. Refer to <https://www.janztec.com/recycling> or contact Janz Tec under recycling@janztec.com for more instructions how and where to return the products.

3.1.2 Germany

All Janz Tec products are registered as B2B custom at the german EAR. Hence Janz Tec products **must not** be disposed to public collection points for used electronic equipment. Refer to §14 of General Terms & Conditions of Janz Tec AG for the details regarding the mutual obligations as to the disposal of Janz Tec products.

The Lithium battery included in the product is registered at "GRS Batterien" and can be disposed to public collecting points for used batteries.

As stated above, used Janz Tec products can also be returned to Janz Tec at you own expense for free-of-charge recycling.

4 Installation



WARNING: Burns Hazard

The product generates considerable amount of heat. The housing transports this heat to the environment and therefore gets hot. **Caution when touching the housing, burns hazard!**

The product can be operated with DC power supply from 9 to 34 V.

4.1 Mounting

The emPC-X is intended for DIN rail mount. Refer to figure 2 for the recommended mounting orientation.

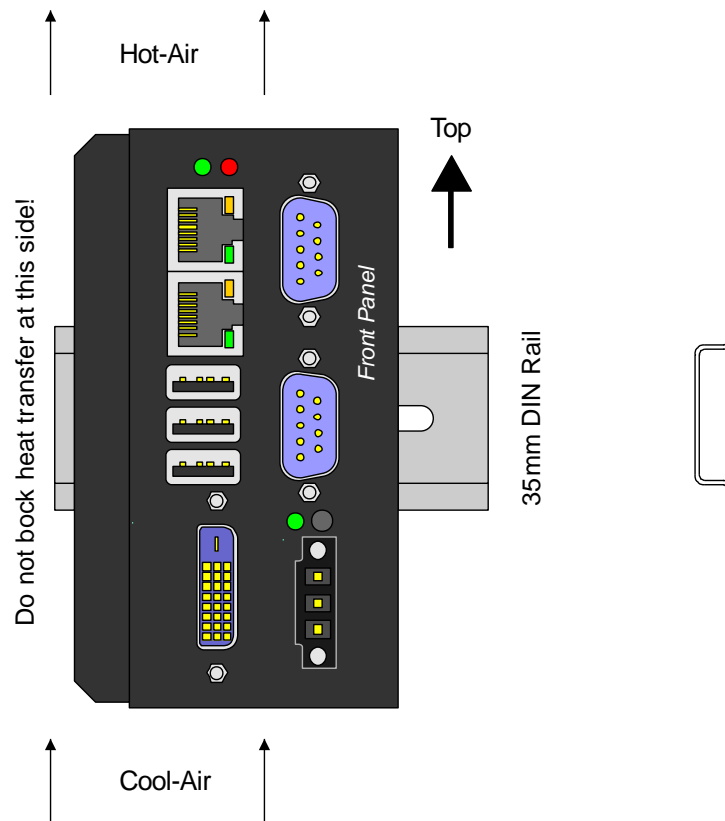

figure 2: emPC-X mounting options



WARNING

This product does **NOT** fulfil the requirements for a fire enclosure according to EN 60950-1. Installation is only permitted above concrete or other non inflammable materials.



CAUTION: Damage

Do not operate the product beyond the specified ambient conditions. Do not cover the vent slots of the product.

Install the product such that the venting holes at the top and bottom of the housing are not blocked.

The ambient temperatures **below, left, right** and in **front** of the product must not exceed the specified maximum ambient temperature.

Cooling requirements depend on the mounting conditions (e.g. nearby heat sources) as well as the actual power dissipation in the product. At light loads, the mounting conditions might be relaxed. It is recommended to check the cooling conditions in the user application. Temperature sensors are available inside the emPC-X.

4.2 Connectors and Operators

The emPC-X is equipped with differing interfaces. The following interfaces are common for all systems: DVI-D, 2 x USB 2.0, 2 x 10/100/1000 Mbit/s Ethernet. Depending on which alternative was ordered additional interfaces are available. The following table shows the standard systems.

Product	Interface	Windows	Linux	Address
emPC-X/0	Serial-0 (Console)	COM2	ttyS1	0x2f8/IRQ3
	Serial-1 (Console)	COM1	ttyS0	0x3f0/IRQ4
emPC-X/1	Serial (Console)	COM1	ttyS0	0x3f0/IRQ4
	CAN	CAN0/mpcan_00	/dev/pcan_0	MOD_BASE
emPC-X/2	CAN0	CAN0/mpcan_00	/dev/pcan_0	MOD_BASE
	CAN1	CAN1/mpcan_01	/dev/pcan_1	MOD_BASE + 0x200
emPC-X/4	CAN0	CAN0/mpcan_00	/dev/pcan_0	MOD0_BASE
	CAN1	CAN1/mpcan_01	/dev/pcan_1	MOD0_BASE + 0x200
	CAN2	CAN0/mpcan_10	/dev/pcan_2	MOD1_BASE
	CAN3	CAN1/mpcan_11	/dev/pcan_3	MOD1_BASE + 0x200

Table 2: Interfaces connected to D-SUB

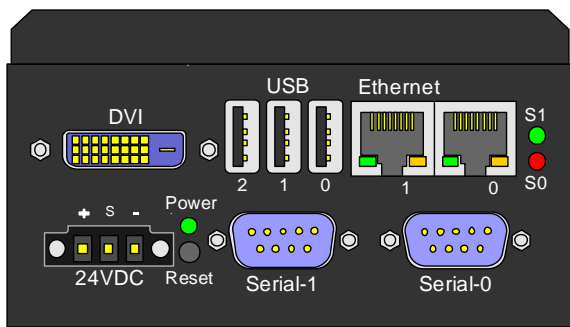

Figure 3: emPC-X/0 interfaces

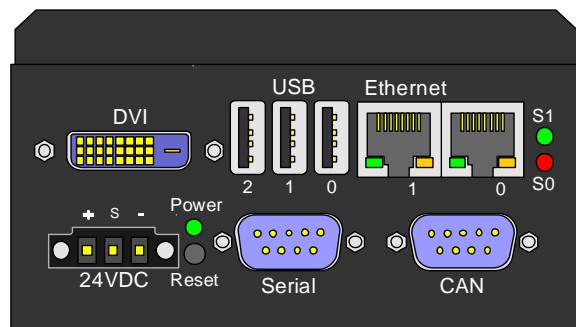

Figure 4: emPC-X/1 interfaces

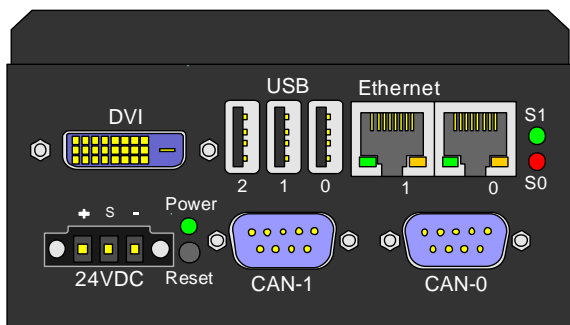

Figure 5: emPC-X/2 interfaces

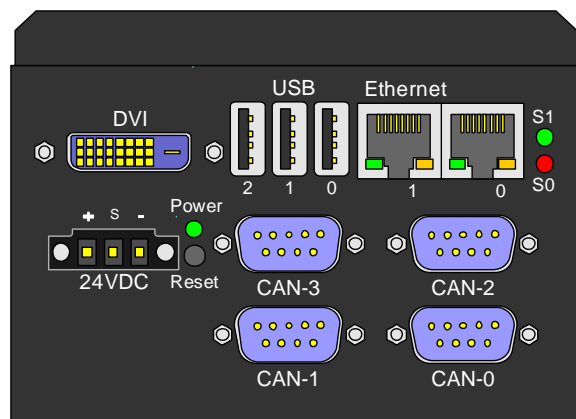
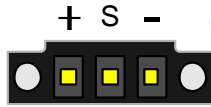

Figure 6: emPC-X/4 interfaces

4.2.1 POWER IN

The system power supply is connected with a 3 pin screw terminal with 5.08 mm pitch.



Pin	Description
1 (+)	+9 ..34 VDC
2 (S)	Control input (0 .. 34 V)
3 (-)	GND

Figure 7: Power connector

Table 3: Power connector pin assignment

A suitable mating connector is Phoenix Contact 1900895. Equivalent Models exist from other vendors.



DANGER: Electrical Shock

The product may only be operated with power supplies which can be considered SELV circuits.



Internal system GND is connected to the housing and routed to the power supply connector.

4.2.2 Graphics connector (DVI)

Combined digital and analog graphics connectors. The digital interface provides single link only.



1	TMDS 2-	13	N/C
2	TMDS 2+	14	+5V
3	SHIELD	15	GND
4	N/C	16	Hotplug detect
5	N/C	17	TMDS 0-
6	DDC clock	18	TMDS 0+
7	DDC data	19	SHIELD
8	N/C	20	N/C
9	TMDS 1-	21	N/C
10	TMDS 1+	22	SHIELD
11	SHIELD	23	TMDS C+
12	N/C	24	TMDS C-

table 4: DVI-D connector

4.2.3 Ethernet Interfaces (Ethernet1 and Ethernet2)

Ethernet interfaces of the motherboard. The Ethernet physics is 10/100/1000BaseT, available through the shielded modular jack at the connector panel. Twisted pair cable can be used to connect to this port.

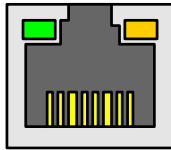

1	MDI0+	5	MDI2+
2	MDI0-	6	MDI2-
3	MDI1+	7	MDI3+
4	MDI1-	8	MDI3-

1

table 5: Ethernet connector

The two LEDs indicate Ethernet status as follows:

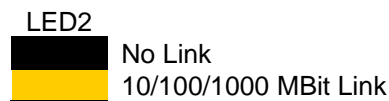

4.2.4 USB type A receptacle (USB0, USB1 and USB2)

Three USB interfaces are available at the connector panel.

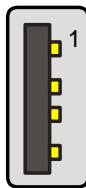

1	+5V, I _{MAX} = 500 mA
2	USB-
3	USB+
4	GND

table 6: USB connector



NOTICE

Although each port can deliver supply current of 500 mA, the overall load on USB0 to USB2 interfaces should be limited to 900 mA to prevent power supply from overheating.

4.1 RS232 (Console)

The RS232 (Console) serial interface is provided by Super IO W83627 chip, hence it is a legacy compatible serial port. The connector is a standard 9 pin D-SUB plug, but the interface is connected with four wires only, table 7 shows the pin out.

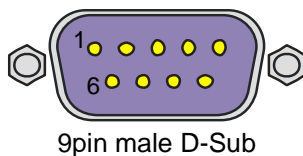

1	n.c.	6	n.c.
2	RxD	7	RTS
3	TxD	8	CTS
4	n.c.	9	n.c.
5	GND		

table 7: RS232 (Console) connector

4.2 RS232

Additional serial interfaces might be implemented by a XR16V2750 dual UART chip. This type of serial port has proprietary implementation over the internal expansion bus. Hence it needs special software driver. For a description of UART registers refer to the EXAR manual. The UART clock input is 14,7456MHz to allow error free generation of standard baud rates. This RS232 variant provides all 8 interface signals as shown in table 8.

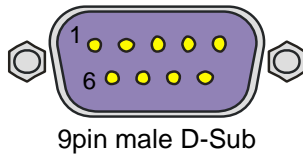

1	DCD	6	DSR
2	RxD	7	RTS
3	TxD	8	CTS
4	DTR	9	RI
5	GND		

table 8: RS232 connector

4.3 RS485

In the RS485 variant, there are only the differential signals D+ and D- provided. The transceiver is enabled to send data, when RTS# of the corresponding UART is low. Hardware can be customized to either receive or not-receive (standard) the transmitted data on the UART's RxD input. Ask Janz Tec for customization regarding this option.

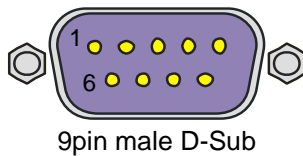

1	n.c.	6	GND
2	D+	7	D-
3	GND	8	n.c.
4	n.c.	9	n.c.
5	n.c.		

table 9: RS485 connector

The bidirectional differential signals D+ and D- are provided. When the transmitter is enabled, and no data is send (1=MARK), then $D+ > D-$ (refer to figure 8).

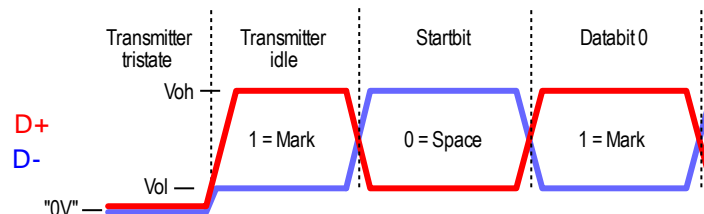

figure 8: RS485 signaling

Note that D+ corresponds to pin "A" of the transceiver chip. However, this is signal B according to the EIA-485 or Profibus standards.

The receiver has the failsafe input feature, which ensures that no data is received when D+ and D- are floating or are shorted (e.g. by the termination resistor).

4.4 CAN

The CAN interface is implemented with a SJA1000 controller chip. The connector is a standard 9 pin D-SUB plug with a pin out shown in table 10. The CAN interface is isolated and has a software switchable 120 Ohm termination.

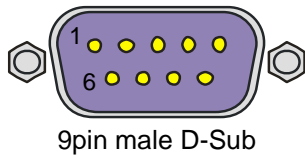

1	n.c.	6	GND
2	CANL	7	CANH
3	GND	8	n.c.
4	n.c.	9	VEXT ¹
5	n.c.		

table 10: CAN connector

¹ This signal is optionally available to provide power to supply an external transceiver module

4.5 SD Card

The optional SD card slot can be accessed from the front panel. It is protected by a cover (see figure 9).

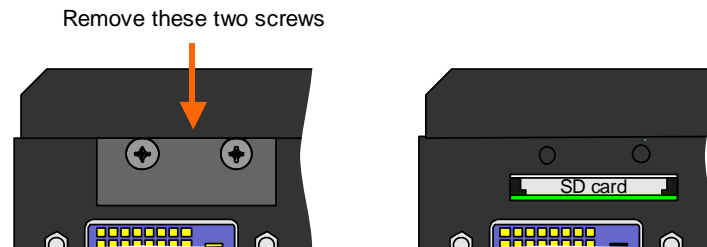

figure 9: emPC-X SD card cover removal

After having removed the SD card cover, push the card to eject it.



NOTICE

Removing and installing the SD card is possible when the system is running. However, ensure that the operating system is ready for card removal before you push the card. Otherwise, you might lose data.

To install the SD card push it into the socket until the card locks. Then install the cover.

5 Maintenance



NOTICE

Always follow common ESD practice when you service the product!

To open the housing, you can remove the back panel or the front panel. Different maintenance tasks require one of them to be removed, others require full disassembly.

Task	Back Panel		Remarks
Replace CFast	remove		
Replace Battery			Complete disassemble

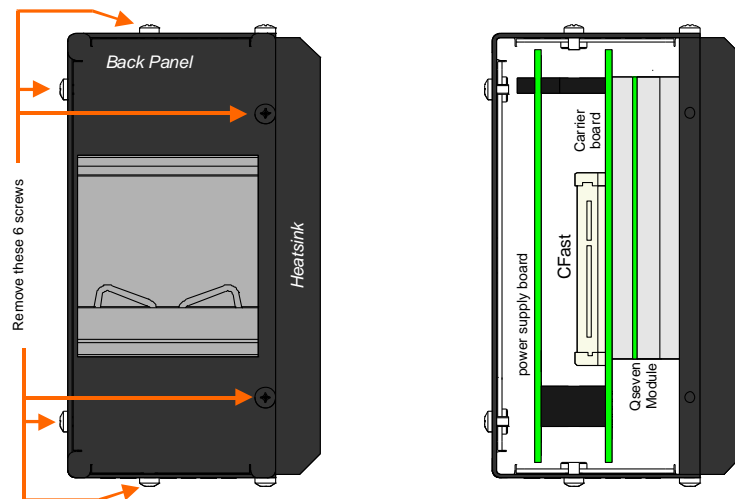

figure 10: emPC-X back panel removal

5.1 CFast Card Replacement



NOTICE

Power must be turned off before removing or inserting the CFast card

Refer to figure 10 to identify the location of the CFast card.

5.2 Battery Replacement



CAUTION : Fire Risk

The installed computer board is equipped with a Lithium battery. Danger of explosion if battery is incorrectly replaced. Replace only with battery of the same or equivalent type (3-volt lithium coin cell battery).

- Do not attempt to recharge the battery.
- Do not disassemble, crush, puncture, short external contacts, or dispose of in fire or water.



NOTICE: Battery approval

The battery must be a compatible battery type: CR2032 (3 Volt lithium coin cell battery). The replacement battery must have a NRTL approval.

Compatible battery type for products with extended temperature specifications: CR2032 (3 Volt lithium coin cell battery) with temperature range -40 .. +85°C or better (Recommended: Murata CR2032X or CR2032W).

The battery is used for backing up the system time when the power supply is removed.

1. Turn off the computer properly through the operating system, then turn off any external devices.
2. Disconnect the power supply from the power inlet and disconnect any external devices.
3. Disassemble the housing and locate the battery on the power supply board
4. Remove the battery from the holder (See figure 11)
5. Insert the new battery (See figure 11)
6. Reassemble the housing

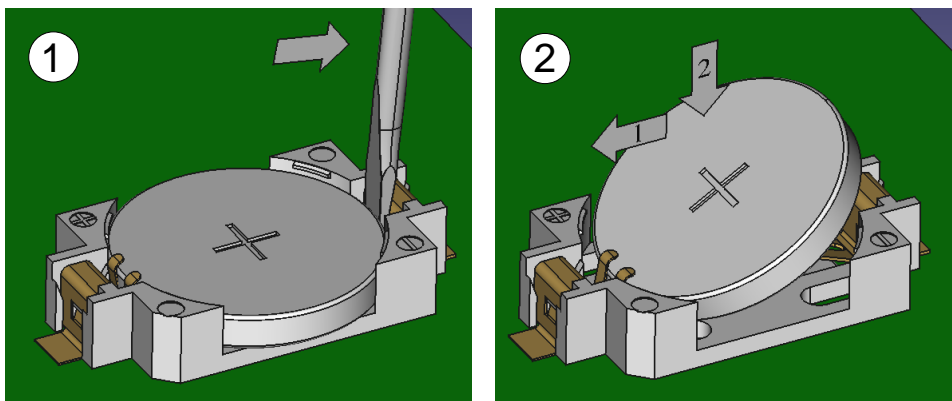

1. Removal: Insert screwdriver at right side and bend so that the battery pops out. Use only gentle force, otherwise the battery holder might be damaged.
The use a plastic tool is preferred to avoid shorting the battery
2. Insertion: Align new battery to the left side of the holder and gently press down on the right side of the battery until the battery snaps into the holder.

figure 11: Removing and replacing coin cell battery

6 Appendices

6.1 Technical Data

emPC-X/A-E3815
emPC-X/A-E3825
emPC-X/A-E3940

Processing Core

CPU	A-E3815: Intel Atom E3815 (1x1.46GHz, 512kB L2 Cache) A-E3825: Intel Atom E3825 (2x1.33GHz, 1MB L2 Cache) A-E3940: Intel Atom x5-E3940 (4x1.6/1.8GHz, 2MB L2 Cache)
Qseven Module	Congatec QA3

Memory

Main Memory	2 GB DDR3L, 1066 MT/s with Intel Atom E38** 4 GB DDR3L, 1066MT/s with Intel Atom E3940
Nonvolatile RAM	128 kB MRAM

Storage

CFast	1 x internal socket with SATA 3 GB/s
SD card (Option)	1 x Socket at front panel

Video

Controller	Chipset graphics: Intel®HD Graphics with support for DirectX11 OpenGL 3.0, OpenCL 1.2, OpenGLES 2.0, full HW acceleration for decode/encode of MPEG2, H.264 , MVC
Memory Interface	Shared with main memory 1 x DVI-D single link connector on front panel, up to 1280x1024 1 x Single channel LVDS on internal connector, up to 1024x768

External Interfaces (connector panel)

Video	1 x DVI-D
Ethernet	1 x 10/100/1000 Mbit/s Ethernet (Ethernet 0: Intel i210) 1 x 10/100/1000 Mbit/s Ethernet (Ethernet 1: Intel i210)
USB	3 x USB2.0 (max 500mA per port, max 900mA all ports in total)
CAN (Option)	SJA1000 controller <ul style="list-style-type: none"> • ISO/DIS 11898-2 (isolated from logic), • software switchable 120 Ohm termination resistor
Serial Port (Option)	Console UART: <ul style="list-style-type: none"> • RS232 (4 wire) • RS485, optionally isolated from logic Xicor 16V2750 (Port expansion): <ul style="list-style-type: none"> • RS232 (full featured) • RS485, optionally isolated from logic

Expansion

iX-Bus	Internal 8/16 bit interface for IO and low speed peripherals
--------	--------------------------------------------------------------

Indicators and Switches

Reset	Pushbutton
Status	LED for power supply status (green)
User LEDs	2 programmable LEDs (S0 – red and S1 - green)

System

Housing	galvanized steel sheet, outside painted
---------	-----------------------------------------

Battery	CR 2032, for real time clock
Temperature Sensor	Accessible via Qseven module I2C
Watchdog	Yes, implemented in Qseven module

Power Requirements

Power Supply	DC power, 9 .. 34 V (lower limit with adjustable UVL)
Inv.-pol. protection	Yes
Fuse	Internal melting fuse in DC in, GND is unfused
potential separation	No, GND (Pin 3 in Table 3) is connected to case
Inrush Current (max)	TBD
Power Dissipation	Without external load or expansion cards
	A-E3815: TBD
	A-E3825: 15W (max)
	A-E3940: TBD

External Load Capabilities

+5V (USB)	Max. 0.5 A per USB port, max 0.9 A for al USB ports in total
-----------	--------------------------------------------------------------

Environmental Specifications

Ambient Temperature operating	A-E3815: 0 .. 50 °C A-E3825: 0 .. 50 °C A-E3940: 0...50 °C
	at sea level, derating of 1 °C per 300 m above sea level to a maximum of 2000 m.
Temperature storage	-20..+75 °C ²⁾
Humidity	5%..95% r.H., non condensing
Protection Class	IP20

Physical Dimensions

Size (WxHxD)	Including connectors and rail mounting bracket	
	2 DSUB:	65.0 x 115.5 x 116.0 mm
	4 DSUB:	82.6 x 115.5 x 116.0 mm
Weight	2 DSUB:	830 g
	4 DSUB:	TBD

6.2 References

These references direct you to manuals and specifications that you might need to know when you attempt to program the product. Most of the documents can be downloaded from the Internet. Look for the WWW servers of the component/chip manufacturers.

- [1] **SJA1000 Product specification**, Philips Semiconductor, Jan 04, 2000
- [2] **ixBus System Reference Manual**, Janz Tec AG

WWW-References

Janz Tec AG

www.janztec.com

6.3 Dimensions

Refer to figure 12 for the housing dimensions.

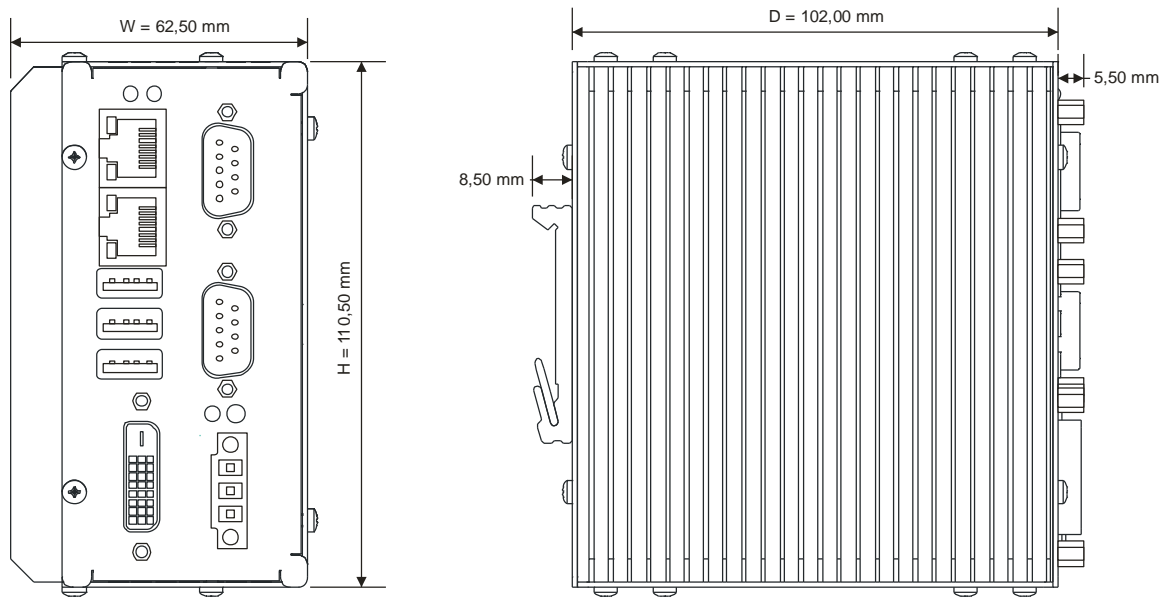

figure 12: housing dimensions (2 DSUB system shown)

emPC-X Systems with different IO options just differ in dimension W

Slot Variant	W
2 DSUB	62.5 mm
4 DSUB	80.1 mm

6.4 Product History

TBD

6.5 Manual History

Version	Release Date	Name	Changes
V1.0	2015-01-19	as	<ul style="list-style-type: none">• Initial release
V1.1	2015-01-22	as	<ul style="list-style-type: none">• Added “Do not cover the vent slots of the product” to the safety instructions• Added additional notes to the section “Mounting”
V1.2	2019-02-12		<ul style="list-style-type: none">• Changed housing colours in illustrations• Changed RS485 self-receipt to non-standard behaviour• Updated battery replacement section• Added sections <i>intended use</i> and <i>disposal and recycling</i>
V1.3	2021-08-09	Tka	<ul style="list-style-type: none">• Added Intel Atom E3940 series
V1.4	2022-06-07	As	<ul style="list-style-type: none">• Updated recycling information